



HOME BATTERY COMPLIANCE

July 1, 2025

A HANDY BOOKLET TO UNDERSTAND THE COMPLIANCE REQUIREMENTS RELATED TO THE BATTERY.

Screenshots have been taken from AS/NZS 5139:2019 for better demonstration.

Photos of actual installation have also been used to demonstrate the compliance vs non-compliance

Disclaimer: All reasonable care has been taken in the preparation of this document. However, no responsibility or liability is accepted for any loss, damage, or consequences arising from reliance on the information contained herein. Users are expected to conduct their own due diligence and consult official sources, including but not limited to AS/NZS 5139:2019, to ensure compliance with applicable regulations and standards.

All common installation scenarios and compliances related to it have been addressed in this booklet. A specific installation scenario may not have been discussed. You are required to check AS/NZS 5139:2019 and local regulations.

Note: Prepared on July 1, 2025.

NO APPLIANCES IN THE CLEARANCE ZONE (ALL RED BLOCKS) THAT ARE NOT ASSOCIATED WITH BESS

35

AS/NZS 5139:2019

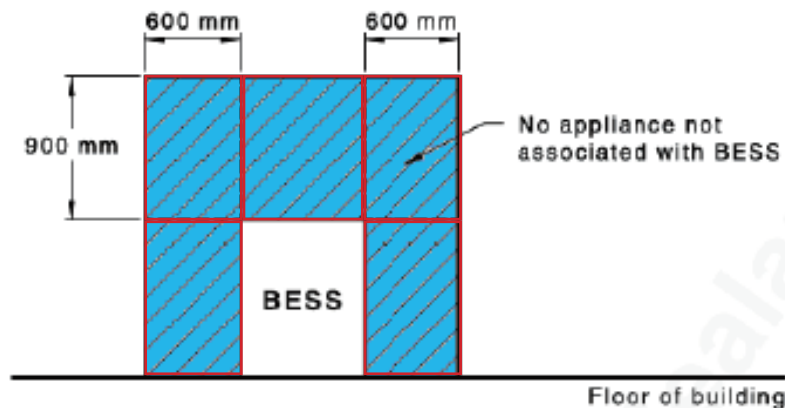

DO

- ✓ Check the accurate measurement
- ✓ Check AS/NZS 3000:2018 & AS/NZS 5139:2019 to find out the list of equipment not allowed.
- ✓ Most common appliances are listed below
- ✓ Call us for further guidance if confused.
- ✓ Battery must not be installed
 - a. On roofs, or
 - b. Within ceiling spaces
 - c. Set into wall cavities.
(This can be a separate section.)

DON'T

- ✗ Don't start the installation if you are not sure
- ✗ Don't assume anything
- ✗ Don't move any appliances away without the customer's written acknowledgement
- ✗ Don't falsify measurements

GENERAL INFORMATION

- Follow this link to get more clarification:
https://www.erac.gov.au/wpcontent/uploads/2021/03/Battery_Energy_Storage_System_02Feb2021.pdf
- A list of appliances that must not be in the clearance zone including—but not limited to— those related to Hot Water Systems (HWS), Heat Pumps, Air Conditioning, BBQs, etc.
- There are separate requirements related to the Gas Meter and Gas Cylinders. Basic information is provided in this booklet. However, local regulations must be referred to find out final clearance requirements.
- NBN box, Switches and isolators, Socket outlets. They are not considered to be electrical appliances as per the definition.



Photo 1



Photo 2

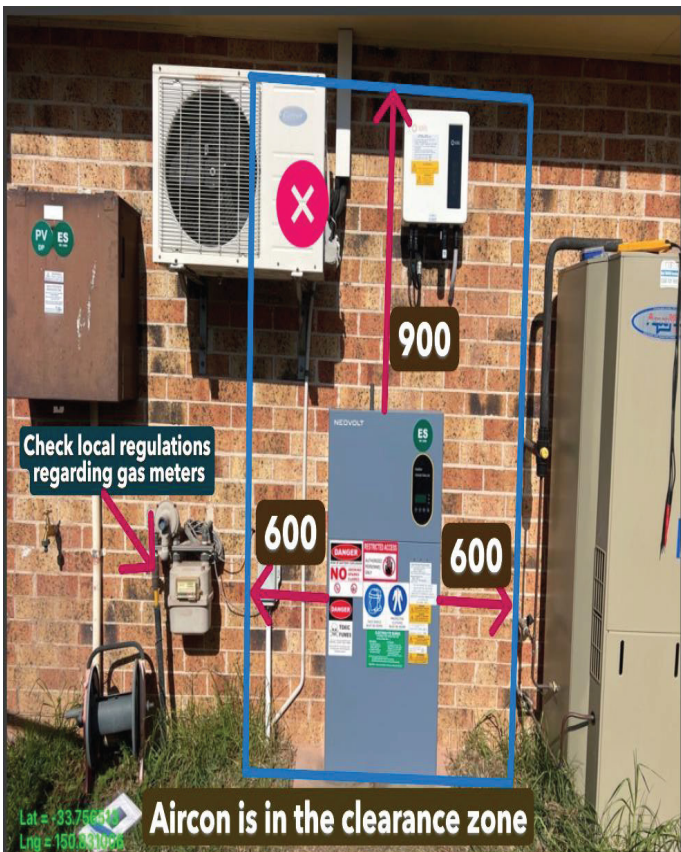

Photo 1

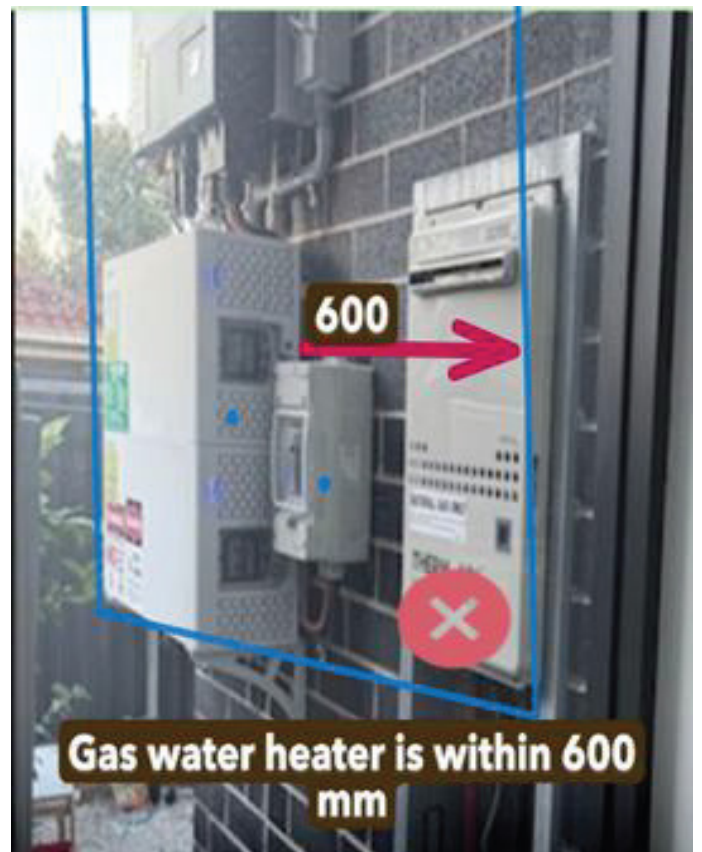
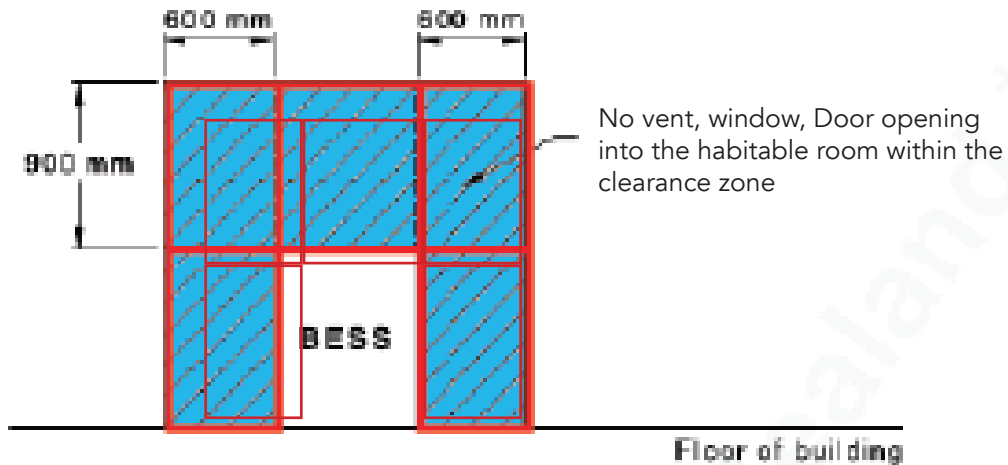

Photo 2

NO VENT, WINDOW, DOOR (OPENING INTO THE HABITABLE ROOM) SHALL BE WITHIN THE CLEARANCE ZONE



DO

- ✓ Check the Room/Space behind the wall of the battery location.
- ✓ Find out the nearest vent, window, or Door.
- ✓ Check if the vent, window, or door is opening into the habitable room.
- ✓ If yes, Move the battery to achieve necessary clearance

DON'T

- ✗ Don't install directly under or in front of a window/vent.
- ✗ Don't ignore habitable room openings.
- ✗ Don't compromise escape routes.
- ✗ Don't falsify measurements!

GENERAL INFORMATION

- A BESS must not be installed within 600mmx600mm x 900mm (as shown in the picture above) of:
 - > a window opening into a habitable room, or
 - > vent(s) including mechanical, electrical, or other ventilation openings to habitable rooms.
- **For NSW:** The Battery must not be installed within 600mm of any exit.
- **All Other States:** Openings that are wider than 900mm, e.g. a garage opening, must allow a person to pass more than 1000mm from the nearest side of the Battery.
- Follow this link to get more clarification:
https://www.erac.gov.au/wp-content/uploads/2021/03/Battery_Energy_Storage_System_02Feb2021.pdf

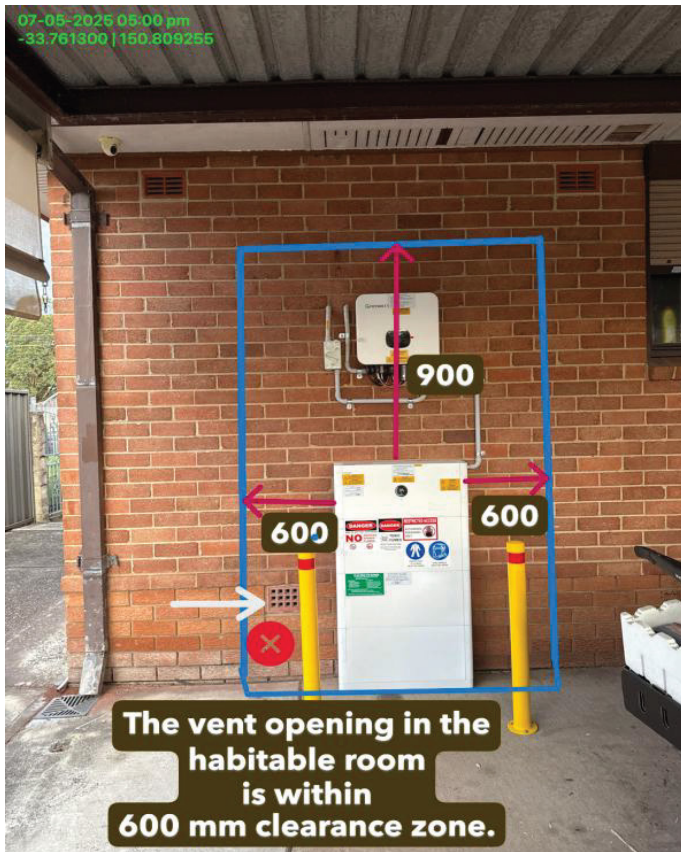

Photo 1



Photo 2

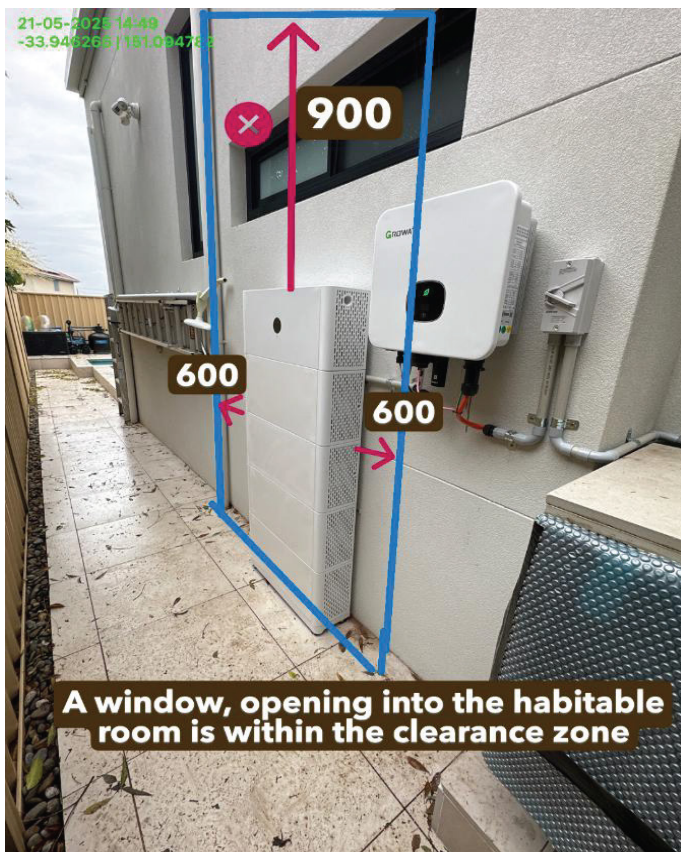

Photo 1



Photo 2

NON-COMBUSTIBLE/FIRE BARRIER REQUIREMENT

37

AS/NZS 5139:2019

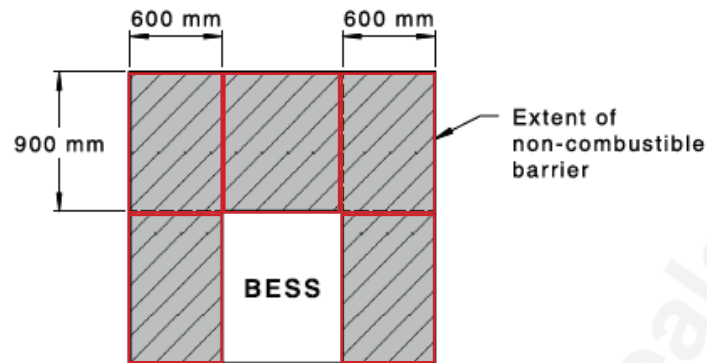

Figure 4.2 — Barrier zones for pre-assembled integrated BESS installed on or near a habitable room facing wall

DO

- ✓ Check the Room/Space behind the wall of the battery.
- ✓ Confirm if it is a habitable room.
- ✓ If it is a habitable room, also confirm if the wall type is non-combustible.
- ✓ If the wall is made of combustible material, you must install a noncombustible fire barrier (for ex., A Fire Rated Cement sheet),
- ✓ The sheet must expand to the full 600mmx600mmx 900mm zone as shown above.

DON'T

- ✗ Don't use flammable or untested materials as a fire barrier.
- ✗ Don't assume that the 'Fire Barrier' is optional.
- ✗ Don't leave gaps between barriers.
- ✗ Don't do partial coverage (Not less than 600mmx600mmx 900mm)
- ✗ Don't install the battery against damaged or warped surfaces where it becomes difficult to install the firebarrier sheet.

GENERAL INFORMATION

- A wall that has a habitable room on the other side requires an additional requirement to install a non-combustible fire barrier on the wall behind the BESS to delay the spread of fire.
- A habitable room is defined in clause 1.3.42 of AS/NZS 5139:2019
- If behind the battery is a **habitable room**, the wall must be **fire-rated or barrier-protected** to prevent fire risk transfer.
- Brick or masonry blocks, concrete, ceramic or clay-based tiles/terracotta, etc. deemed to be a non-combustible barrier and doesn't require any additional non-combustible barrier.
- Firmly mount the barrier sheets to the wall to prevent movement or collapse.
- Fire-rated Cement sheets with a thickness of 6mm are considered industry best practice.



Compliant installation of Cement Sheets

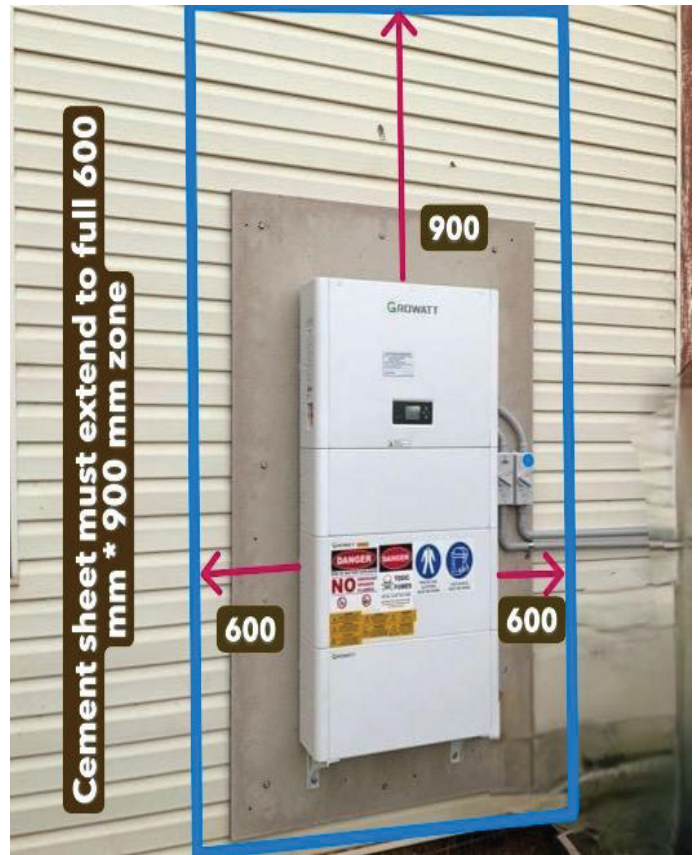

Non-compliant Installation, as explained

INTEGRATED BESS (WHERE THE INVERTER IS PART OF THE BATTERY MODULES)

The integrated BESS, where the inverter is built-in into battery modules, is considered to be as one fully integrated battery system.

Check out the explanation as per AS/NZS 5139:2019 below that mandates the compliant requirements to be met exactly the same way as met for non-integrated BESS.

For example, when you count 900mm for top clearance, you must start measuring from the very top edge of the integrated BESS and NOT where the battery modules start.

1.3.59

pre-assembled integrated BESS

battery energy storage system equipment that is manufactured as a complete, pre-assembled integrated package. The equipment is supplied in an enclosure with the PCE, battery system, protection device(s) and any other required components as determined by the equipment manufacturer

Note 1 to entry: A pre-assembled BESS may be delivered in separate modular parts and assembled on site.

1.3.55

power conversion equipment

PCE

electrical device converting and/or manipulating one kind of electrical power from a voltage or current source into another kind of electrical power with respect to voltage, current and/or frequency

Note 1 to entry: Examples include but are not limited to d.c./a.c., inverters, d.c./d.c. converters and charge controllers.

35

AS/NZS 5139:2019

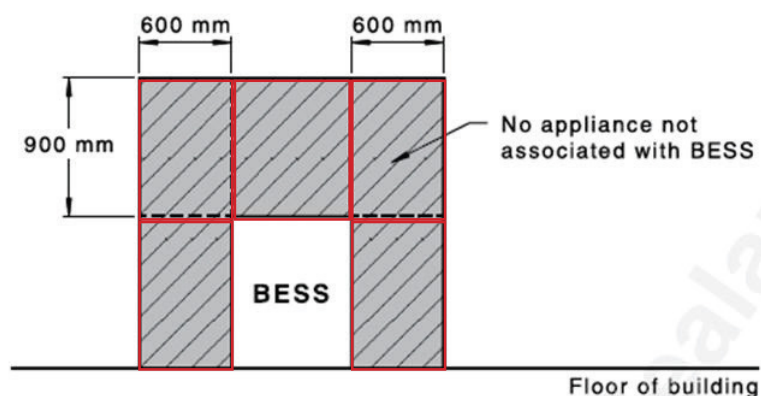

Figure 4.1 — Restricted zones for equipment not associated with the pre-assembled integrated BESS

GAS CYLINDER AND GAS RELIEF VALVE CLEARANCE ZONE

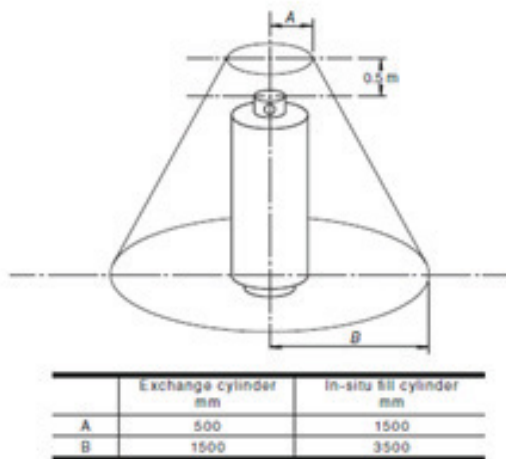
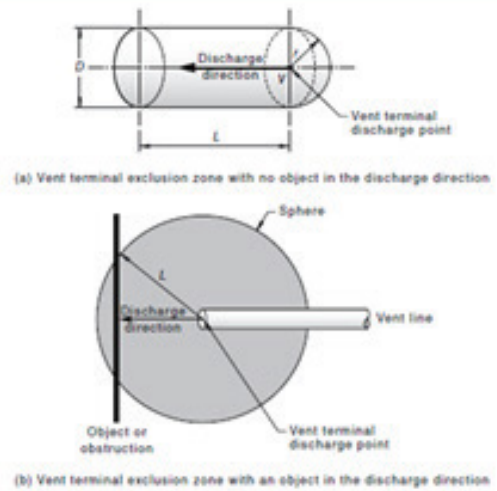

FIGURE 4.18 HAZARDOUS AREA PRESENTED BY A GAS CYLINDER OUTDOORS FOR HEAVIER-THAN-AIR GASES



Vent terminal diameter, V (not shown)	Exclusion zone, m		
	L	D	r
Not exceeding 50 mm	1.5	1	0.5
Exceeding 50 mm	1.5T	T	0.5T

NOTES:

- 1 T = [vent terminal diameter (mm), V]/(50), in metres.
- 2 The exclusion zone shown in Figure 4.13(a) depicts a space consisting of a cylinder in the discharge direction and a hemisphere in the opposite direction of discharge for the vent terminal discharge point.
- 3 The exclusion zone only applies up to 200 kPa.

FIGURE 4.19 EXCLUSION ZONES PRESENTED BY A GAS RELIEF VENTING TERMINAL

DO

- ✔ Check in a hazardous area as defined in AS/NZS 3000, refer i. Figure 4.18 for distances from gas cylinders and,
- ✔ ii. Figure 4.19 for distances from gas relief vent valves.
- ✔ Check local regulations in your state for any further clearance requirements

DON'T

- ✘ Don't install the battery within the clearance zone

GENERAL INFORMATION

- Speak to DNSP or the Electrical Authority in your state for further information

MECHANICAL PROTECTION REQUIREMENTS

4.2.2 General

Pre-assembled integrated BESSs shall be protected from mechanical damage, environmental and other external influences, Where the location chosen may expose the pre-assembled integrated BESS to influences that might be reasonably expected then they should be considered as part of the installation conditions, e.g. damage caused by a vehicle if a system is being installed in a carport or garage.

DO

- ✔ Protect the BESS by installing the required number of bollards from a vehicle impact.
- ✔ Bollards should typically be 100mm in diameter, 1.2m in height. These criteria shall be revised against actual installation conditions.
- ✔ Must be embedded securely in concrete.
- ✔ Must be installed on solid and stable ground.

DON'T

- ✘ Don't install bollards Off-Centre.
- ✘ Don't install an insufficient number of bollards.
- ✘ Don't use makeshift materials as bollards.
- ✘ Bollards installation shall not obstruct access to the battery.

GENERAL INFORMATION

- Refer AS/NZS 5139:2019 Clauses 4.2.2.1 & 5.2.2.1)
- Mechanical protection involves physically safeguarding a battery system and its components from potential impact or damage, especially in areas accessible to vehicles or subject to change over time.
- This applies even if the current homeowner doesn't use it for parking, as future use may change. Non-fixed items like benches or cupboards do not provide reliable protection, as they can be moved later.
- The gap between the battery and bollard must be sufficient enough to provide safe access for service and maintenance personnel. The recommended clearance is: 600 mm.
- Single Battery Stack: Install 2 bollards – one on each side of the stack.
- Two Battery Stacks: 3 bollards may be acceptable if they provide adequate protection for both stacks or else Install 4 bollards – two for each stack.



SMOKE ALARM REQUIREMENTS

DO

- ✔ Install in enclosed spaces near battery.
- ✔ Use compliant alarms.
- ✔ Install on ceiling, away from corners.
- ✔ Test after installation

DON'T

- ✘ Don't install too close to battery.
- ✘ Don't use Non-Compliant brands.

GENERAL INFORMATION

- When the battery is installed in enclosed in door spaces / indoor /Garage, a working smoke alarm must be installed that meets the AS3786 compliance requirements and installed in the vicinity of the battery.
- A semi-enclosed area that poses a risk of gas accumulation or fire hazards must also have working smoke alarm.



